



# **Web Cleaner**

## **1 / 2**



**Air Line**



# Operating instructions for Web Cleaner 1 Web Cleaner 2

## Contents

1	Product description .....	5
1.1	Application .....	5
1.2	Function principle .....	5
1.3	Danger warnings .....	6
2	General safety instructions .....	6
3	Installation .....	7
3.1	Mounting .....	7
3.2	Pressurised air connection .....	8
3.3	Suction connection .....	10
3.4	Electrical wiring and high-voltage supply .....	10
4	Start-up .....	10
5	Trouble shooting .....	11
5.1	Trouble shooting in the ionization systems .....	11
5.2	Trouble shooting in the air supply .....	11
5.3	Trouble shooting in the suction system .....	11
6	Maintenance .....	12
6.1	Regular maintenance .....	12
6.2	Changing ionizing bars .....	12
7	Technical data Web Cleaner .....	13



# 1 Product description

## 1.1 Application

Web Cleaner can be mounted above, under or adjacent to the material surface to be cleaned. It neutralises electrostatic charges and removes detrimental contamination by means of pressurised air and suction.

The appliance is not for use in atmosphere where there is a danger of explosion (Ex-zone). Models suitable for this are available.

The ambient temperature may not exceed +50°C-

The appliance must not come into contact with dampness, wetness or aggressive substances.

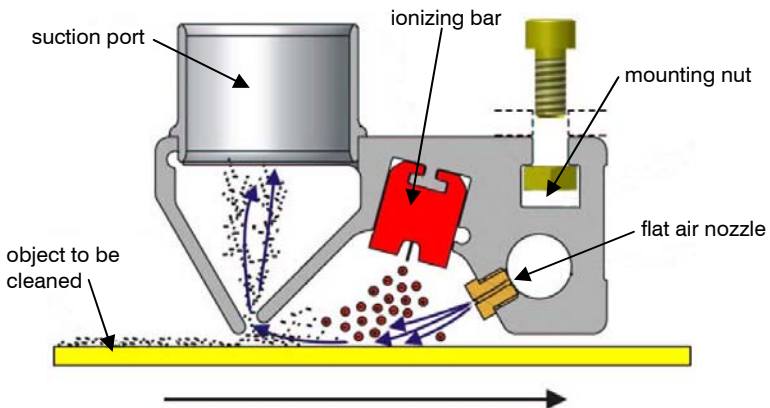

fig. 1: scematic diagram

## 1.2 Function principle

The ionizer (fig.1) generates positive and negative ions. The flat air nozzles transport these ions to the workpiece surface. The airstream from these nozzles in combination with the ionization cause dust particles to be released from the surface. In the case of Web Cleaner 1 and 2 contamination particles are transported to the suction channel and selectively sucked off.

## 1.3 Danger warnings

When damage to the appliance is visible and electrical defects are noticed, switch off the appliance immediately!



**Danger!** Risk of injury due to the transport of material near the appliance! Safety equipment, e.g. safety shields and on/off switch to facilitate immediate shut-down of the equipment and emergency stop switches before start-up! Do not approach the appliance unless the entire equipment is switched off! Before initial start-up ensure that all tools and unnecessary articles have been removed.

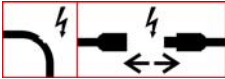

**High voltage!** Defective ionizers, defect cables and high-voltage plugs can cause injuries due to electrical current! Installation of the high-voltage components only when not live! Improper installation can lead to damage of the high-voltage cables! Plug the coaxial plug in and out only when the supply is switched off! Comply with the operating instructions of the ionizing bars and power packs!



**Danger!** Faulty compressed-air lines and connectors can lead to severe injury! Fit the compressed-air lines and connectors only when not under pressure.



**Note!** Persons with a heart pacemaker should keep a safety distance of 50 cm from the ionizing bar. An expert's report on the influence of heart pacemakers can be requested from the manufacturer.

## 2 General safety instructions

In operating practice safety can only be achieved when all required measures are taken. It is the operator of the appliance's obligation to plan these measures and to monitor their implementation. Faulty operation or misuse are a threat to the life and limb of the operator as well as endangering the appliance and other valuable equipment.

In particular, the operator must ensure that the appliance is only used for the purpose stated, and that the appliance is operated in faultless, functional condition.

It must be assured that only sufficiently qualified and authorised personnel operate, maintain and repair the appliance, that these personnel are regularly instructed in all applicable questions of work safety and environment protection. They must know the operating instructions and in particular the safety and warning notices are in place and are readable.

These operating instructions must be kept beside the appliance. It must be assured that all persons who are involved in working on the appliance have access to reading the operating instructions at all times. Separate operating instructions exist for ionizing bars and power packs.

The following symbols are used in these operating instructions. The main purpose of these symbols is mainly to draw the reader's attention to the text of the safety instructions next to them.



This symbol indicates danger for life and health of persons and that danger exists for machinery, material or the environment.



This symbol indicates danger for life and health of persons and that danger exists for machinery, material or the environment due to dangerous electrical voltage.

### 3 Installation



**Danger!** Risk of injury due to transporting of material near the appliance! Do not approach the appliance unless the entire equipment is switched off!



**Danger!** Faulty compressed-air lines and connectors can lead to severe injury! Fit the compressed-air lines and connectors only when not under pressure!



**Danger!** Defective ionizers, defect cables and high-voltage plugs can lead to injury through electrical current! Improper installation can lead to damage of the high-voltage cables! Plug the coaxial plug in and out only when the power pack

is switched off! Comply with the operating instructions of the ionizing bars and power packs!

Setup work, mounting and installation of the appliance may only be performed by qualified persons according to the safety instructions. Before beginning the installation the appliance must be checked for transport damage. Setup position is optional.

#### 3.1 Mounting

The Web Cleaner can be mounted on machines and manufacturing plant using the T-groove (fig. 1) with hexagon screws (for screw diameter and max. permissible torque for the screws see table 1). The screws should be retightened after two weeks.

Table 1 shows the operating gap between the appliance and the material surface (fig. 2). If the appliance is mainly used for discharging, the operating gap can be extended past the maximum limit.

When positioning the appliance the transport direction of the workpiece must be taken into account.

Table 1

	Screw diameter	Max. applied torque	Operating gap (min – max)	Optimal operating gap
Web Cleaner 2	M10	55 Nm*	1 mm – 5 mm	2 mm
Web Cleaner 1	M6	8 Nm*	1 mm – 3 mm	

\* The applied torque may not exceed the max. permitted torque of the screw..

fig. 2: Transport direction T and operating gap W

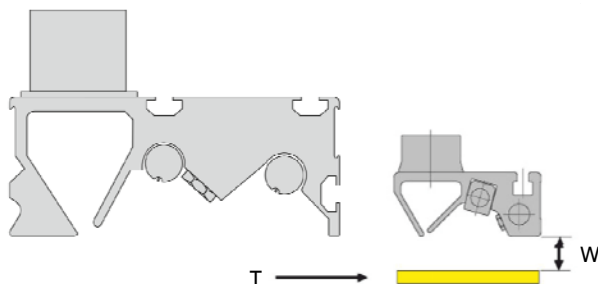

In the case of low weight materials, suitable measures should be taken to maintain the minimum gap between the appliance and the material, e.g. spacer, material guides, deflector rollers to stabilise the material.

Machine components which are earthed may not be positioned in the immediate vicinity of the ionizing bars.

No additional components may be installed between the ionizing bars and the workpiece surface (exception: electrically neutral slide elements if required).

### 3.2 Pressurised air connection

The compressed-air supply is effected via a filter control valve with water and oil separator to which the Web Cleaner appliance must be connected. The compressed air must be at least in accordance with quality class 3 (ISO 8573).

Diametrical constrictions such as kinks, a radius three times the hose diameter and quickfit connectors in the compressed-air hose must be avoided. Keep compressed air hoses as short as possible. Table 2 shows the operating pressures at the appliance. It may be necessary to set a higher pressure value at the regulator if there is a pressure loss in the supply hose. The compressed-air consumption is shown in diagrams 1 and 2.



Table 2

	Operating pressure (pmin – pmax)	Optimal operating pressure
Web Cleaner 2	1.3 – 3.5 bar	2.5 bar
Web Cleaner 1	1.5 – 3.0 bar	2.25 bar

Diagram 1



Diagramm 2



If the Web Cleaner 2 is equipped with economy nozzles the operating pressures sink. The air consumption is the 70% lower compared to Web Cleaner 2 with standard air nozzles.

### 3.3 Suction connection

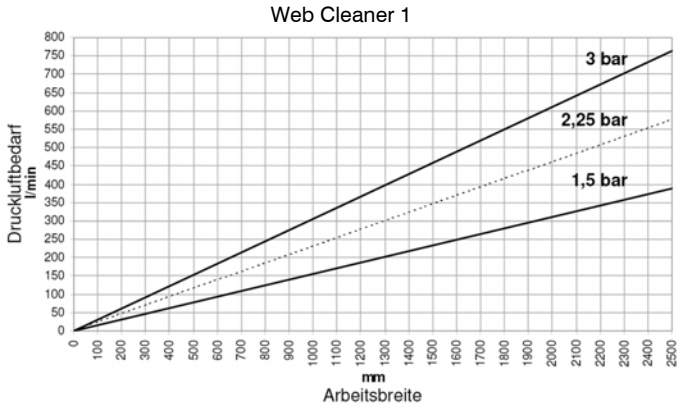
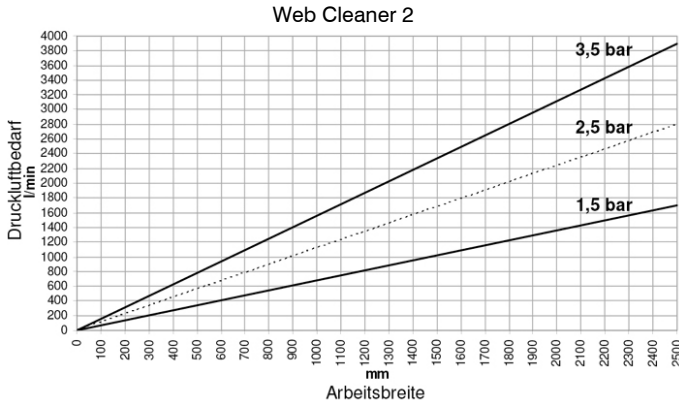
Attach suction hoses to the suction ports of the Web Cleaner (diameter see table 3) using hose clamps. Lead suction hose to the adapter, to the suction unit or to the existing exhaust air system. Keep the hoses as short as possible. Diametrical constrictions such as kinks and a radius three times the hose diameter must be avoided in order to reduce pressure losses.

Table 3

	Diameter suction ports
Web Cleaner 2	55 mm
Web Cleaner 1	32 mm

### 3.4 Electrical wiring and high-voltage supply

Only power packs from HAUG GmbH & Co. KG may be used for the high-voltage supply. The high-voltage cables for the supply of ionizers are connected to the power pack via a plug connection. Detailed information is given in the operating instructions for the ionizing bars and power packs.

## 4 Start-up



**Danger!** Risk of injury due to transporting of material near the appliance! Safety equipment, e.g. safety shields and on/off switch to facilitate immediate shut-down of the equipment must be assured by the operator! Activate all safety equipment and

emergency stop switches before start-up! Do not approach the appliance unless the entire system is switched off! Before initial start-up ensure that all tools and unnecessary articles have been removed.



**Danger!** Faulty compressed-air lines and connectors can lead to severe injury! Fit the compressed air lines and connectors only when not under pressure!



**Danger!** Defective ionizers, defective cables and high-voltage plugs can cause injury by electrical current! Improper installation can cause damage to high-voltage cables! Coaxial plugs for the ionizing bars must only be plugged in and out

when the power pack is switched off! Observe the operating instructions for the ionizing bars and the power packs!

1. Switch on power pack for the ionization unit.
2. Switch on air pressure supply and set operating pressure.
3. Switch on suction units. Optimise suction power of the entire system by adjusting the gap between appliance and material surface (via appliance mounting), the air pressure via the filter control valve and/or the supply volume via the throttle flap at the radial ventilator.

## 5 Trouble shooting



**Danger!** Risk of injury due to material transport near the appliance! Activate all safety equipment and emergency on/off switches before start-up! Do not approach appliance until the entire system is switched off! Before initial start-up ensure that all tools and unnecessary articles have been removed.



**Danger!** Faulty compressed-air lines and connectors can lead to severe injury! Fit the compressed-air lines and connectors only when not under pressure!

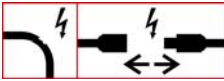

**Danger!** Defective ionizers, defective cables and high-voltage plugs can lead to injury due to electrical current! Improper installation can lead to damage of the high-voltage cables! Coaxial cable plugs for the ionizing bars may be plugged in and out only when the power pack is switched off! Observe the operating instructions for the ionizing bars and the power pack.

### 5.1 Trouble shooting the ionization systems

1. Check the installation; the installation check may only be carried out by a qualified electrician.
2. Is the supply voltage identical with that shown on the manufacturer's specification?
3. Is the power pack switched on?
4. Is the power pack functioning properly? Detailed information on the power packs are given in the appropriate operating instructions.
5. Are the ionizing bars functioning properly? Check the function of the ionizing bars with testing device Multicheck (12.7229.000); changing bars see chapter 6 maintenance.

### 5.2 Trouble shooting the air supply

1. Are all connections made correctly?
2. Is compressed air present?
3. Is the filter control valve open and showing the correct pressure setting?

### 5.3 Trouble shooting the suction system

1. Are the suction hoses at the suction ports tightly attached?
2. Are the suction hoses undamaged?
3. Are the suction hoses constricted, buckled or blocked?
4. Is the throttle flap open?

## 6 Maintenance

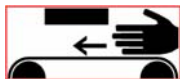

**Danger!** Risk of injury due to transported material near the appliance! Do not approach the appliance unless the entire equipment is switched off!



**Danger!** Faulty compressed-air lines and connectors can lead to severe injury! Fit the compressed-air lines and connectors only when not under pressure!



**Danger!** Defective ionizers, defective cables and high-voltage plugs can lead to injury due to electrical current! Improper installation can lead to damage of the high-voltage cables

plugs for the ionizing bars may only be plugged in and out, when the power pack is switched off! Observe the operating instructions for the ionizing bars and the power packs!

### 6.1 Regular maintenance

The appliance must not come into contact with dampness, wetness or aggressive substances! Check the ionizing bars' function regularly and above all after cleaning, using testing device Multicheck (12.7229.000)! Ionizing bars may only be cleaned by qualified personnel!

The ionizing bars should be cleaned as required, but at least every two weeks using special cleaning agent SRM 1 (10.7220.000) and the special cleaning system RS 2 (10.7218.004). The Web Cleaner unit (in particular the air nozzles and the intake area) should be cleaned when contaminated, however every four weeks.

Table 4

Maintenance job	Maintenance intervals
Cleaning ionizing bars	2 weeks
Checking ionizing bar function	2 weeks
Cleaning Web Cleaner appliance	4 weeks

### 6.2 Changing ionizing bars

1. Release detach screws as shown in fig. 3.
2. Withdraw the bar carefully in the direction shown.
3. To fit new bar, reverse the procedure.

fig. 3

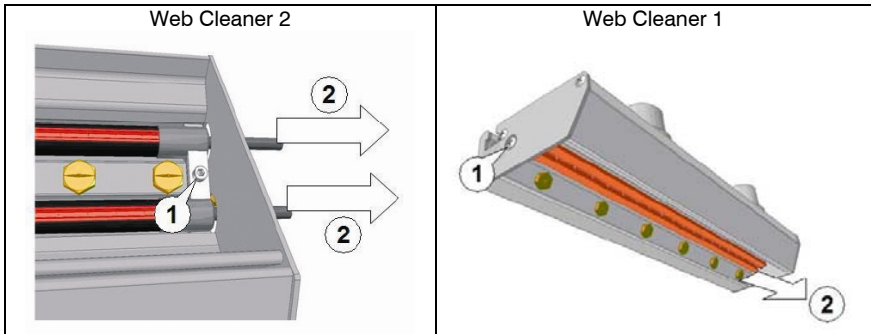

## 7 Technical data Web Cleaner

Mark	Web Cleaner 2	Web Cleaner 1
Dimensions of cleaning profile (WxH) (mm)	185 x 85	80 x 35
Ionizing bars	≥ 300 mm: 2 x EI PSA < 300 mm: 2 x EI RN  (optional: EI RA <sup>(1)</sup> , EI VS, EI VSA <sup>(1)</sup> )	1 x EI PSA
Vacuum socket (mm)	Ø 55	Ø 32
Nozzles	Flat jet nozzles	
Possible working width (mm)	70 – 2000 (4900) <sup>(2)</sup>	45 – 2000 (2850) <sup>(2)</sup>
Weight per working width (kg/100 mm)	2.2	1.0
Weight per working width step 100 mm/kg	+1.5	+0.3

(1) When using ionizing bars EI RA or EI VSA:

The ionizing bar has to be 20 mm longer than the cleaning profile

(2) Maximale special length (mm)

## Type key

Model	Order-No.
Web Cleaner 2	04.0100.xxx R/L zzz
Web Cleaner 1	04.0110.xxx R/L zzz
Example: 04.0100.200 L 200	

R/L Right (R) or left (L) construction. Mounting side in transport direction facing appliance

xxx Working width in cm

zzz HT cable length in cm

## Accessories

Type	Description	Order-No.
SRM 1	Special cleaning agent	10.7220.000
RS 2	Cleaning system for discharging bars	10.7218.004
Multicheck	Function testing device	12.7229.000
Power pack	HT power pack with solenoid valve, motor protection switch (control box), suction hose, adapter, distributor, etc.	on request
Filter control valve	mit Spezial-Feinstfilter, Manometer, Wasser- und Spezial-Ölabscheider	on request
Low pressure blower		on request

## Spare parts

Part	Order-No.
Flat profile nozzle for Web Cleaner 2	X-3768
Flat profile nozzle for Web Cleaner 2, lower air consumption	X-3769
Flat profile nozzle for Web Cleaner 1	X-6848
Ionizing bar: Type is mentioned on the specification plate or stamp.	

## Dimensions

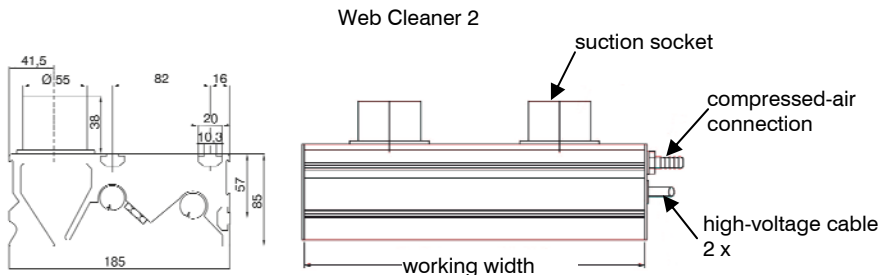

Web Cleaner 1

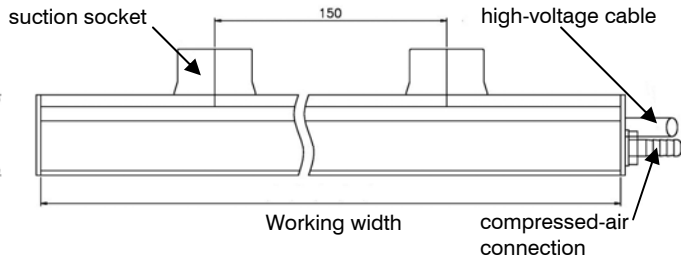
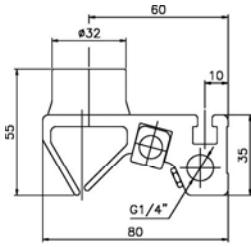

made by



## **HAUG GmbH & Co. KG**

Friedrich-List-Straße 18  
D-70771 Leinfelden-Echterdingen  
Telefon: +49 711 / 94 98-0  
Telefax: +49 711 / 94 98-298

**www.haug.de**  
E-Mail: [info@haug.de](mailto:info@haug.de)

## **HAUG Biel AG**

Johann-Renfer-Strasse 60  
CH-2500 Biel-Bienne 6  
Telefon: +41 32 / 344 96-96  
Telefax: +41 32 / 344 96-97

**www.haug-ionisation.com**  
E-Mail: [info@haug-biel.ch](mailto:info@haug-biel.ch)